

# DOOR CLOSER SERIES 416 INSTALLATION INSTRUCTION

**STANDARD MOUNT  
(PULL SIDE)**

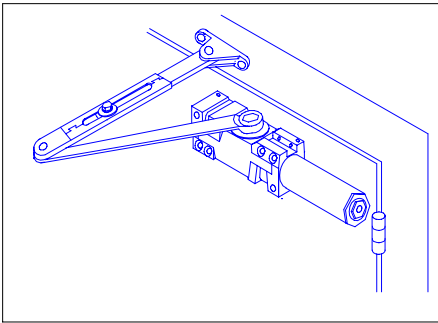

**TOP JAMB MOUNT  
(PUSH SIDE)**

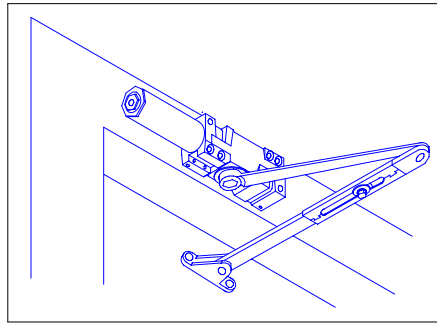

**PARALLEL MOUNT  
(PUSH SIDE)**

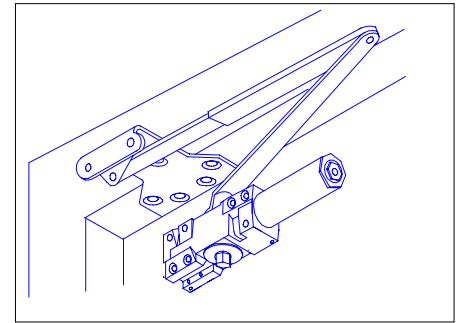

MAXIMUM DOOR WIDTH		FULL TURNS REQUIRED
EXTERIOR DOORS	INTERIOR DOORS	
—	5 lb-f*	5 TURNS C.C.W.
8.5 lb-f*	34"	2 TURNS C.C.W.
30"	38"	0 TURNS
36"	48"	5 TURNS C.W.
42"	54"	10 TURNS C.W.
48"	60"	15 TURNS C.W.

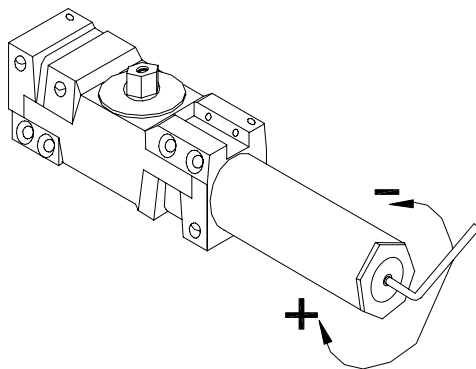
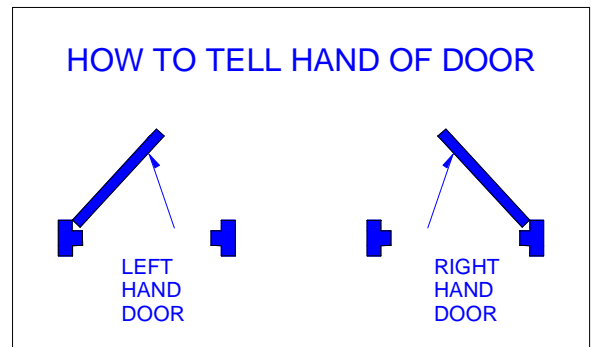

**Spring Power Adjustment**

## CONTROL RANGE

Back Check

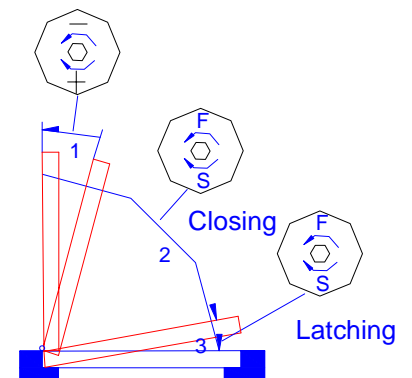

# PARALLEL ARM INSTALLATION

## CLOSER MOUNTED ON DOOR ON PUSH SIDE

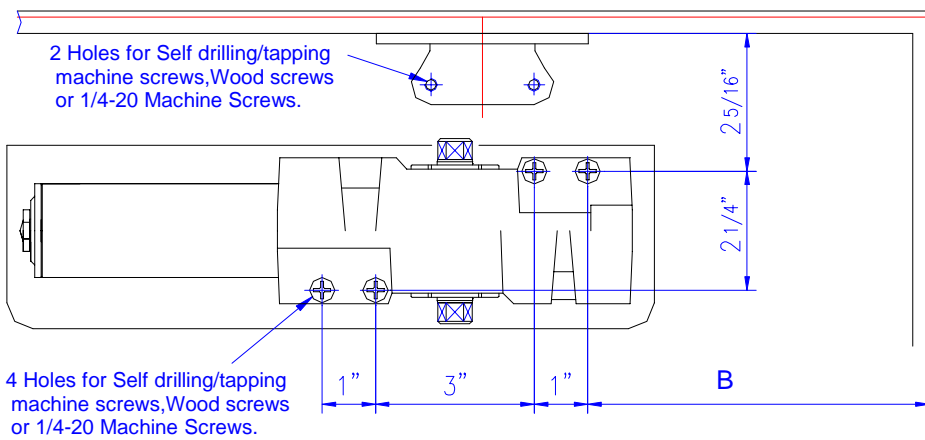
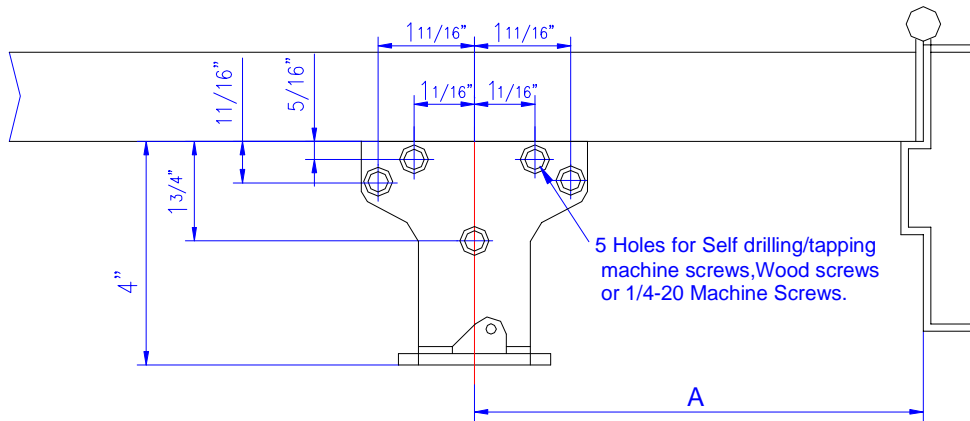

### INSTALLATION DIMENSIONS

OPENING	"A"	"B"
TO 100°	9-7/16"	8-1/4"
TO 120°	8-5/8"	7-5/16"
OVER 140°	7-7/8"	6-1/2"

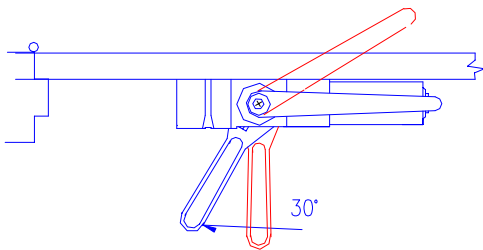

1. Before installation, (parallel arm), turn Back Check selector valve (found on the opposite side of closer) ALL THE WAY IN (CLOCKWISE).
2. Adjust spring power to match door width as indicated by chart on page 1.
3. Mount closer on door as dimensions shown. Tube end toward latch. If pivots are used, locate closer and parallel bracket from CENTERLINE OF PIVOT.
4. Place open end wrench on bottom shaft and turn toward hinge jamb about 30° and then place main arm on top shaft, insert arm screw into top of shaft and tighten.
5. Attach parallel bracket on frame as dimensions shown.
6. Attach rod and shoe to parallel bracket as shown.
7. Insert rod in forearm, and then insert main arm to closer parallel to door. Then insert forearm set screw and tighten.

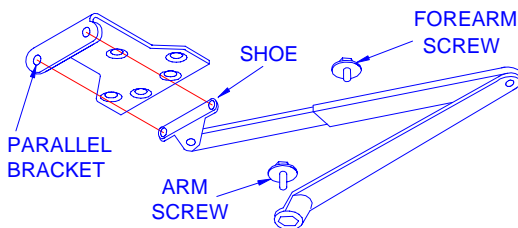

### REGULATION:

A 'Normal' closing time from 90° open position to door stop position is 4-6 secs, evenly divided between main swing speed and latch swing speed. Use socket key (furnished) to adjust speed. To slow main speed of door, turn regulating screw nearest shaft clockwise. To slow latch speed, turn regulating screw nearest hinge clockwise.

### BACK CHECK

To increase back-check force, turn regulating screw nearest hinge clockwise. DO NOT USE ABRUPT BACKCHECK OR EXPECT DOOR CLOSER TO ACT AS A DOOR STOP.

### COVER

Place insert in proper cutout, then push cover against door frame. Tighten both cover screws securely.

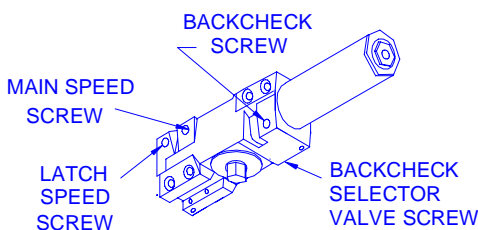

# STANDARD INSTALLATION

## CLOSER MOUNTED ON DOOR ON PULL SIDE

2 Holes for Self drilling/tapping machine screws, Wood screws or 1/4-20 Machine Screws.

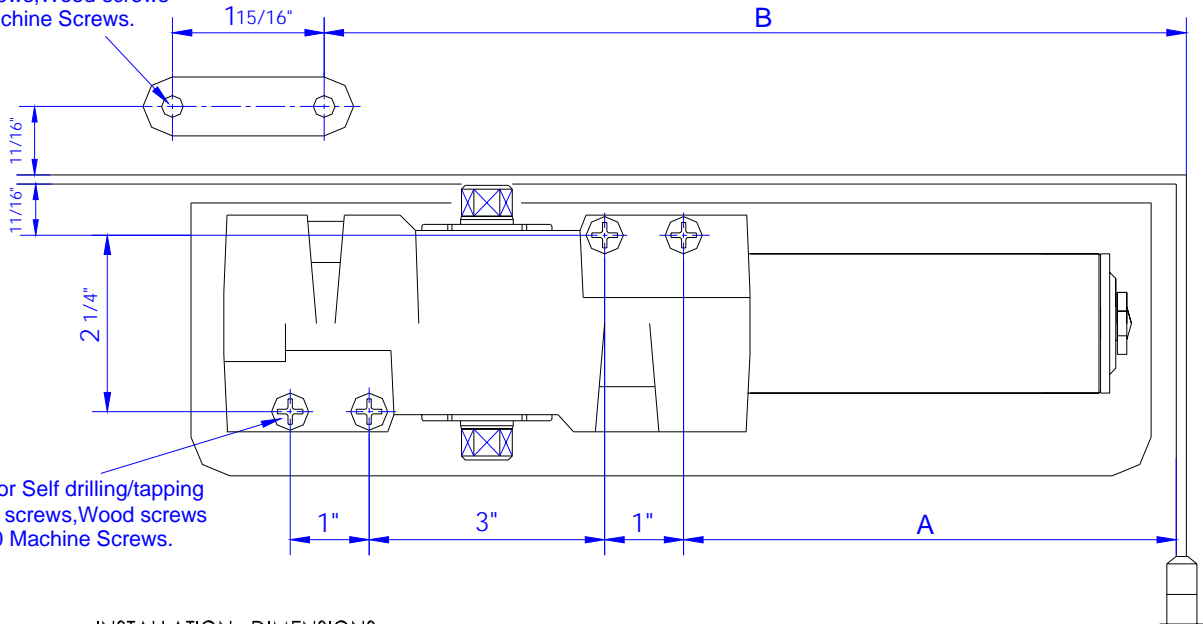

4 Holes for Self drilling/tapping machine screws, Wood screws or 1/4-20 Machine Screws.

### INSTALLATION DIMENSIONS

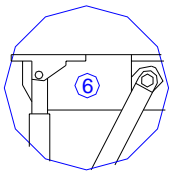

OPENING	"A"	"B"
TO 100°	7-5/16"	11-13/16"
TO 130°	6-1/4"	10-13/16"

1. Adjust spring power to match door width as indicated by chart on front page.
2. Mount closer on door as dimensions shown. Tube end toward hinge. If pivots are used, locate closer and shoe from CENTERLINE OF PIVOT. (For offset pivots, please increase the marked dimensions by 1/8")
3. Place main arm on top of shaft 100° to closer body, insert arm screw into top of shaft and tighten.
4. Attach shoe to frame as shown. (if more latching power is required, rotate shoe 180°)
5. Open door and insert rod in forearm.
6. With forearm at right angle to door (90°), insert forearm set screw and tighten.

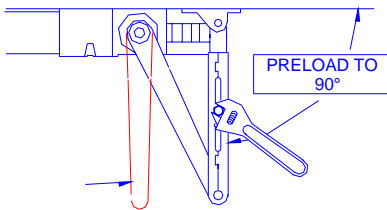

### REGULATION:

A 'Normal' closing time from 90° open position to door stop position is 4-6 secs, evenly divided between main swing speed and latch swing speed. Use socket key (furnished) to adjust speed. To slow main speed of door, turn regulating screw nearest shaft clockwise. To slow latch speed, turn regulating screw nearest hinge clockwise.

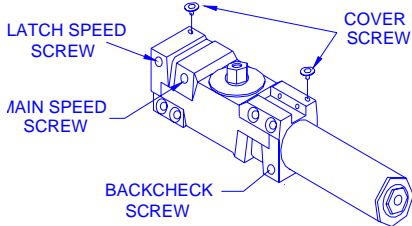

### BACK CHECK

To increase back-check force, turn regulating screw nearest hinge clockwise. **DO NOT USE ABRUPT BACKCHECK OR EXPECT DOOR CLOSER TO ACT AS A DOOR STOP.**

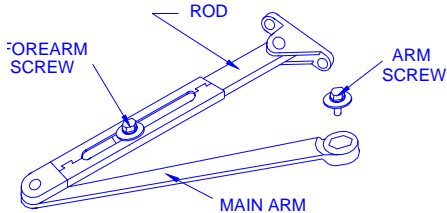

### COVER

Place insert in proper cutout, then push cover against door frame. Tighten both cover screws securely.

# TOP JAMB INSTALLATION

## CLOSER MOUNTED TOP JAMB ON PUSH SIDE OF DOOR

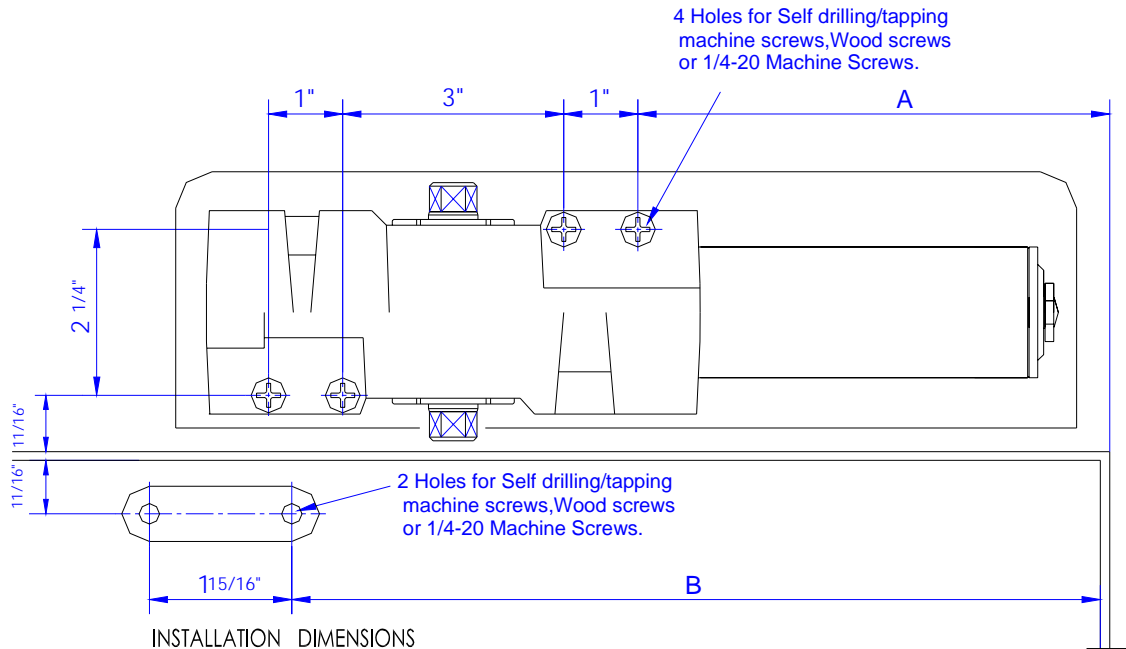

INSTALLATION DIMENSIONS

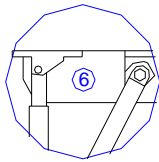

OPENING	"A"	"B"
TO 100°	7-5/16"	11-13/16"
TO 130°	6-1/4"	10-13/16"

1. Adjust spring power to match door width as indicated by chart on front page.
2. Mount closer on jamb as dimension shown. Tube end toward hinge. If pivots are used, locate closer and shoe from CENTERLINE OF PIVOT. (For offset pivots, pls increase the marked dimensions by 1/8")
3. Place main arm on top of shaft 100° to closer body, insert arm screw into top of shaft and tighten.
4. Attach shoe to frame as shown. (if more latching power is required, rotate shoe 180°)
5. Open door and insert rod in forearm--for reveal 2 5/8" through 4 13/16" use long rod. For reveals 4 7/8" to 8" use FOREARM EXTENDER (ROD)--available from dealer.
6. With forearm at right angle to door (90°), insert forearm set screw and tighten.

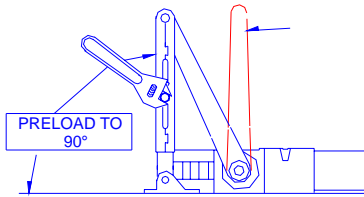

### REGULATION:

A 'Normal' closing time from 90° open position to door stop position is 4-6 secs, evenly divided between main swing speed and latch swing speed. Use socket key (furnished) to adjust speed. To slow main speed of door, turn regulating screw nearest shaft clockwise. To slow latch speed, turn regulating screw nearest hinge clockwise.

### BACK CHECK

To increase back-check force, turn regulating screw nearest hinge clockwise. DO NOT USE ABRUPT BACKCHECK OR EXPECT DOOR CLOSER TO ACT AS A DOOR STOP.

### COVER

Place insert in proper cutout, then push cover against door frame. Tighten both cover screws securely.

